

INSTRUCTION MANUAL

for installation and operation of solid fuel cookers

W300, W300 lux and W320 b



CONTENTS

1. Introduction.....	3
2. Technical specifications and description.....	3
2.1. Technical specifications.	3
2.2. Description.	4
3. Cooker assembling.	10
4. Cooker operation.....	10
4.1. Fuels.	10
4.2. Control devices.	10
4.3. Initial ignition of the cooker.....	11
4.4. Ignition during exploitation.	11
4.5. Ventilation requirements.....	12
4.6. Heating during the transitional period.	12
5. Important instructions for fire-precaution and safety regulations.....	12
6. Cleaning.....	13
7. Possible defects and their causes.....	13
8. Equipment completion.	14
9. Recycling and waste disposal.....	14
Appendix №1	15

1. Introduction.

We congratulate you on the excellent choice!

We hope that your new solid fuel cooker will make much more conveniences in your household. The solid fuel cooker is designed for cooking and heating. It can be used in kitchens and villas but it is not intended to be built in kitchen furniture. The solid fuel cooker is made and tested in accordance with the requirements of the European standard EN 12815 and it responds to the approved technical documentation. For the sake of convenience we will use the name “cooker” from now on.

You may expect that you will have the opportunity to use your cooker for the purpose with which it was made, for a long period of time, and with the least possible servicing. That is why we have a request for you, which is only for your benefit:



Do not leave the instructions unread. The assembly and the exploitation of a cooker are connected with different legal obligations, which are explained in this instruction. According to the laws and regulations for safety, when using an appliance of such class, the buyer and the user of the cooker are obliged, with the help of this instruction, to inform themselves for the assembling and the right operation of the appliance.

The correct installation, careful exploitation and care for the cooker are of great necessity for its perfect functioning and longevity.

By keeping the instruction in a good condition, you will always be able to inform yourself about the right maintenance of the cooker before using.

2. Technical specifications and description.

2.1. Technical specifications.

The technical specifications of the cooker are given in the table Appendix №1

Dimensions: width -930 mm, depth - 623 mm, height -874 mm.

Oven dimensions: width -411 mm, depth -490 mm, height -221 mm.

Flue socket: Ø150 mm.

Fuel type and fuel mass per hour: dry wood logs -3.18 kg/h.

Distance to adjacent combustible materials: 80 cm –in front.

When a thermo resistant base is using, it has to peep out from the firedoor 50 cm –in front and 30 cm – sideways.

Model	Distances to adjacent combustible material side	Distances to adjacent combustible material rear
	[cm]	[cm]
W300	40	40
W300 lux	40	40
W300 Lux (color)	40	40
W320 b	40	40

2.2. Description.

The main components of the cooker are:

W300

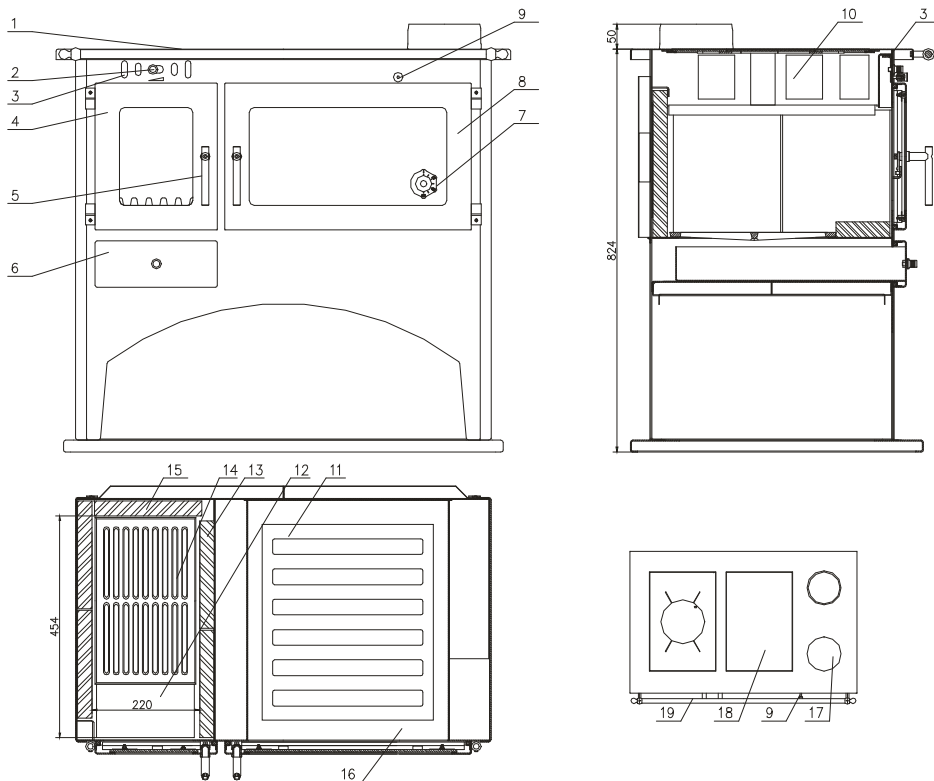
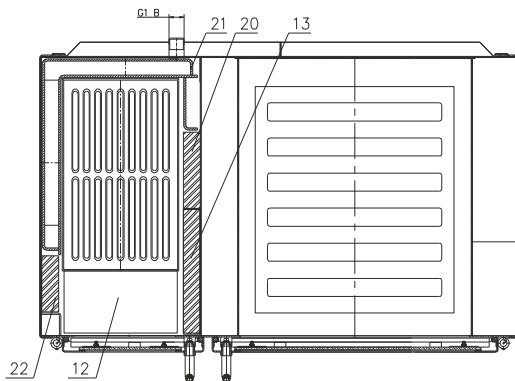

Fig.1

- 1.Body; 2.Knob; 3.Secondary air inlet control; 4.Firedoor; 5.Handle; 6.Ashpan;
- 7.Thermometer; 8.Oven door; 9.Knob; 10.Flap; 11.Grill; 12.Fireclay brick 30x110x220;
- 13.Fireclay brick 30x220x260 (2pcs); 14.Firegrate; 15.Fireclay brick 30x220x300 (3pcs);
- 16.Removable bottom plate; 17.Servicing access door; 18.Top plate; 19.Towel rail.

Fig.1a (rest is at Fig. 1)

W320 b

20. Fireclay brick 30x135x260;

21. Integral water boiler;

22 Fireclay brick 30x98x300

Fig.1b (rest is at Fig. 1)

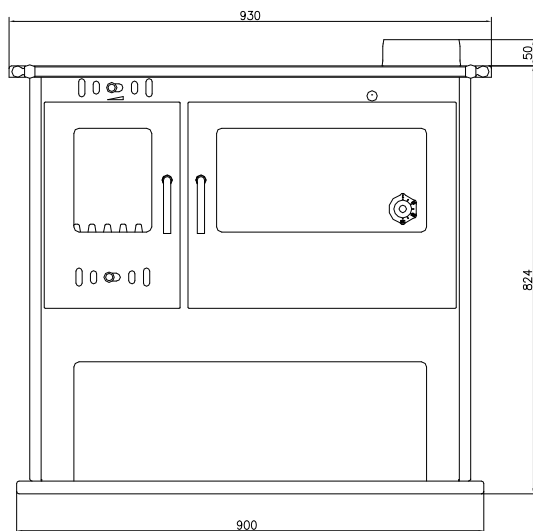
W300 Lux

Except these parts and components the cooker consists of:

Glass

The mounted glass stands up to 850°C of temperature difference, so it cannot be damaged by the high temperature which is achieved when the cooker is working. But it could be damaged by a mechanical influence when installing or transporting the cooker, or by putting big wooden logs into the firebox.

The glass belongs to the spare parts which are quickly worn out, and that is why it is not included in the warranty conditions.

Polluting the glass with soot

The construction of the cooker helps during exploitation not to pollute the glass with soot. The soot is accumulated only when there is bad burning, which may be caused by the following reasons: the static pressure and the dimension of the chimney do not comply with the needed parameters for the cooker, the air flow necessary for the combustion is stopped too early, or the right fuel is not used. In order to keep the glass as clean as possible from soot, the wood logs must be placed in such a manner that the cut surface is not facing to the glass.

We cannot influence to those factors and that is the reason why we cannot guarantee that the glass will not be polluted with soot..

Refractory plates

The firebox is supplied with refractory plates. These plates keep the heat and give it back into the firebox in order to increase the burning temperature. The higher is the burning temperature, the higher is the effectiveness of the burning process. As a result of too high temperatures or mechanical influences the refractory plates might be damaged. Very temperatures can be formed if the flue draught is too high, the secondary air inlet control is fully open and the ashpan is not close to the front panel. In this case the burning process is uncontrolled. Under mechanical influence it is understood e.g. throwing a wood log into the firebox or using bigger wood logs.

The refractory plates might be easily exchanged. If there is only a crack then it is not necessary to change them. It is necessary only in case when the metal parts between them or under them can be visibly seen.

The refractory plates are quickly worn out, and that is why they are not included in the warranty conditions.

Sealing

The sealing of the cooker are made of special glass fiber and does not content asbestos. This material is worn out during usage and the sealing must be periodically exchanged. Your shopkeeper could order these sealing to us.

The sealing is quickly worn out parts, and that is why they are not included in the warranty conditions.

Bottom grate

The lower part of the firebox is supplied with cast-iron grate. This grate could be blocked up by nails in the wooden material, small wooden parts, the residue, etc. You are advised to clean regularly the grate in order to keep its functionality.

When using inappropriate fuel or reaching high temperatures due to incorrect servicing, the grate could be permanently damaged.

The grate is quickly worn out, and that is why it is not included in the warranty conditions.

Paint

The cooker is painted in highly temperature-resistant paint. This paint is resistant to high temperatures, but it is not resistant to moisture. Please do not put any objects on the paint. When dust eventually accumulates then clean by brush or dry towel, but not by wet towel or water.

When the cooker is set to work for the first time it is necessary to leave the paint to be heated for a few hours to be baked and to reach its maximum thermal stability. During that period do not put anything on the cooker or do not touch the outer surface, so that it can remain unaffected. The smell which is produced is caused by the baking of the paint and disappears after a few hours. That is why the room should be well aired.

If as a result of overheating or incorrect servicing the color changes into white-grey, or a stain of rust appears or a part of the surface is damaged, then it is not a problem. You may order a spray in the appropriate color to your shopkeeper.

Handles and Knobs

The handles and knobs of the cooker are made of brass or nickel-plated. This is an advantage because they cannot be worn out. The handles and knobs are heated to such a degree as the front part of the cooker that is why they must be serviced by using a heat-resistant glove.

Oven

The temperature of the oven depends from the burning intensity and from the quantity of the fuel. Primary air control sets the burning stage and it regulates very well the oven temperature.

If you like to heat oven we recommends increasing temperature by ensuring bright fire. There is a thermometer pos.№7 on the glass of the oven door pos.№8 for easier temperature controlling.

If you like to bake a dish we recommend using a grill pos.№14, which can be put on the bottom of the oven or on the side profiles.



Caution! When using the oven put more fuel –the volume of the flue gasses increase and the heating is better and uniform!

When the oven is not using, we recommend leaving oven door open to heat premises better.

Integral water boiler

Purchased by you cooker with an integral boiler gives you the great possibility of heating the nearby premises with radiators.



Your cooker with an integral boiler is designed to work in a water heating system under the maximal operation pressure:

- for “open” system under 1 bar;
- for “close” system under 2 bar;

There is an integral boiler into combustion chamber of the cooker with water heating output according to Appendix №1. The heat output of the connecting loads must be in accordance with the heat output indicated into Appendix №1.

When connecting the water heating system the following rules and recommendations should be observed:

- **The design and the connection of the water heating installation should be obligatory made by an authorized organization! The installation should conform to all standard documents which are in force (in reference with the operation and safety)!**
- Before connecting the installation, it is advisable to calculate the heat loss in the particular case. In case of connecting loads with greater heat output, than the declared one in the Appendix №1, a cooling down of the heating surfaces of the integral boiler occurs, which leads to condensation, pitching and harshly reducing of its heating output.
- **At “open” water heating system** the installation should be connected to the atmosphere with an opened expansion container. Between the cooker and the expansion container not any blocking components should be connected.
- **At “closed” water heating system** safe protecting components should be integrated in the installation, which does not allow exceeding of the working pressure in the cooker over 2 bar.
- Deaeration in each branch and component of the installation should be ensured, in each moment of its operation, and the cooker as well.
- In the installation, immediately near the integral boiler, in the lowest point, drains tap not less than ½” should be mounted.
- All components of the installation should be ensured against freezing, especially if the expansion container or other parts of it are situated in non heated rooms.
- At installations with forced circulation, the pump should be ensured with long term power supply device –automatic mode (UPS). We recommend the circulation pump to be switched on and switched off by means of thermostat, doubled with manual electric switch
- When an old installation is used, then it should be repeatedly washed from the accumulated filths, which could be precipitated on the walls of the integral boiler.
- The circulation water should **not** be drowned off the installation during the non-heating season.
- For cookers with an integral boiler it is better to clean the surfaces of the boiler from soot and resinous matters at least once a month.
- By inserting appropriate isolation materials between the wall and the radiators you will achieve radiation heating whose advantages are proved.
- This integral boiler provides another opportunity -installing a coil into the boiler for warm sanitary water.



The manufacturer cannot guarantee the work of the water heating installation, except for the cooker.

In case of incorrect connecting caused by increased pressure an inflation of the integral boiler a welding rupture occurs. The manufacturer does not take any responsibility for such defects.

INSTALLATION DIAGRAM

For connecting a cooker with an integral boiler for “open” heating system under 1 bar

- 1.Valve;
- 2.Deaerator;
- 3.Radiator;
- 4.Cooker;
- 5.Collector;
- 6.Pump thermostat;
- 7.Thermometer;
- 8.Expander tank-open;
- 9.Overflow drain;
- 10.Manometer;
- 11.Hot water pipes;
- 12.Cold water pipes;
- 13.Pump;
- 14.Filter;
15. Turncock for filling and emptying.

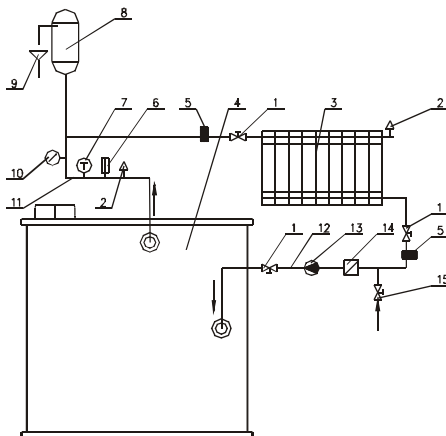

INSTALLATION DIAGRAM

for connecting a cooker with an integral boiler for “close” heating systems under 2 bar
(type B*)

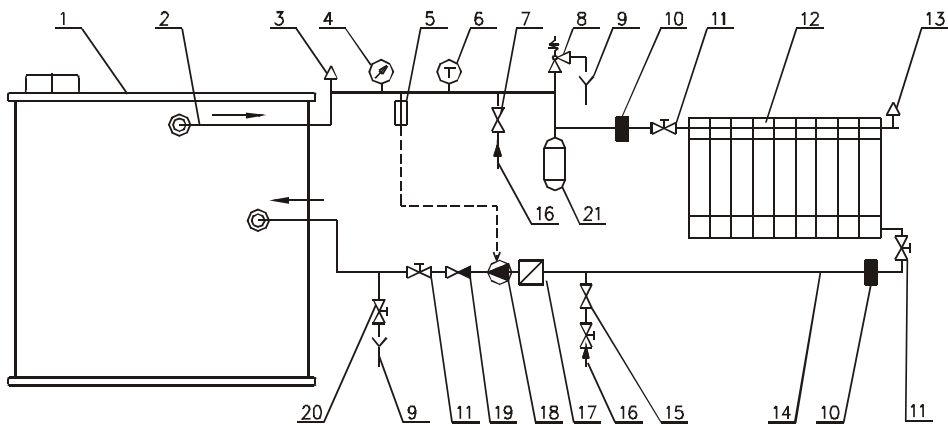

- 1.Cooker; 2.Hot water outflow; 3.Automatic deaerator; 4.Manometer; 5.Electrical thermostat;
- 6.Thermometer; 7.Safety thermo-valve (up to 85°C); 8.Safety hydraulic-valve (up to 2 bar); 9.Overflow drain;
- 10.Collector; 11.Turncock for filling and emptying; 12.Radiator; 13.Deaerator; 14.Pipeline cold

water; 15. Automatic filling group (up to 1.5 bar); 16. Entrance from pipeline; 17. Filter; 18. Pump; 19. Valve; 20. Run off drain; 21. Expander tank-close.



It is not allowed to put the cooker into operation if it is not connected to the heating system. The manufacturer does not take any responsibility if this condition is not observed!

3. Cooker assembling.

It is necessary the following conditions to be kept in order to ensure a safe and correct work of the cooker:

- The cooker should be installed in rooms with sufficient air flow which is required for the combustion;
- The chimney should be high enough (at least 5 meters and $\Phi 200$);
- The cooker should be installed only to non combustible walls and the distance to them should be at least 40 cm. from the back and from the sides;
- If there are any combustible materials or constructions the stove should be installed at least on 80 cm. from them.
 - Chimney pipes must be at least of 50 cm of any combustible materials or constructions;
 - If there are any combustible materials or constructions, the top plate of the cooker should be away from them at least of 100 cm;
- After the installation of the cooker it is attached to the chimney through chimney pipes $\varnothing 150$ mm. The connections between the separate chimney pipes and the socket should be tight. The chimney pipe should not enter into the chimney.

4. Cooker operation.

4.1. Fuels.

The most appropriate fuels are dried wood logs . The wood logs, stored in the open under sheds, reach a humidity level of 10-15% after 2 years, when they are most suitable for combustion. We recommend to burn wood dried as much as possible. The maximum heat output is reached after burning wood logs dried for at least 2 years period of time.

The fresh cut wood has little calorific effect, high humidity and burns poorly –they extract a lot of flue gases and additionally contaminate the environment. This leads to minimizing the longevity of the cooker and chimney as well. The increased condensate and tar content in the flue gases leads to blocking up the flue pipes and the chimney, and an appreciable impurity of the glass. When using them, the heat output of the cooker falls to 50%, and the fuel consumption grows twice.

It is not recommended to use the following fuels in the cooker: wet or tarred wood, shavings, culms, high calorific coals, polymers, paper and cardboard (except for the ignition).



Do not use liquid fuels.

Do not use the cooker like a furnace for burning waste matters.

If the cooker is used for burning unalloyed fuels then the warranty is not valid.

4.2. Control devices.

Before the first ignition of the cooker pay attention to the function of all control devices.

The primary air passes through the ashtray, the grate and goes into the firebox. Primary air is necessary for faster ignition. The amount of air depends from the distance of the ashtray to the front panel of the stove.

Secondary air provides the fire with the required for the combustion oxygen and assists for the better combustion of the fuel. The quantity of the secondary air is controlled through the regulator pos.3, mounted on the front panel. The secondary air regulator should not be closed when the cooker is working. In many cases the secondary air regulator has been closed shortly after the ignition, despite our directions, in order to reduce the fuel consumption. This leads to limitation of the flow of oxygen, which bothers the combustion and the glass is covered with soot. Also there are harmful emissions which may cause burning in the chimney.

We recommend closing primary and secondary air controls when the cooker is not working to keeping it warm for a longer period.

As the heat output of your cooker depends on the height of the chimney, the precise control of the necessary air for the combustion is done by trial and error.

Position of the secondary air inlet control means:

“closed  open”.

Ignition flap (pos 10).

The cooker is fit with an ignition flap pos.10 for easier initial burning. It is opened by pulling the lever by the handle pos. 9. When the ignition flap is open it provides a direct connection between combustion chamber and chimney. When the cooker burns well the ignition flap must be fully closed. The cooker is designed to work at nominal heat output with a fully closed ignition flap.

To maintain the burning fuel must be added periodically which are well placed over the whole grate..

4.3. Initial ignition of the cooker.

At the first ignition of the cooker pay attention to the following:

- Take all the supplementary tools out of the ashpan.
- It is allowed at the initial ignition to pull the ashpan out and after the good burning to close it.
- The regulator for the secondary air control has to be fully open.
- During the first ignition it is necessary the door of the firebox to be left slightly open, in order to prevent the sealing of the fire door to be stuck on the paint.
- The first ignition must be slow and still, with little quantity of sticks and paper. After burning them you may put two or three wood logs.

4.4. Ignition during exploitation.

Your cooker is designed and intended for intermittent condition of burning.

At each ignition you must do the following:

- It is allowed at the initial ignition to pull the ashpan out and after the good burning to close it.
- The secondary air control is opened.
- Put the basic combustion materials, ignite them and close the door. After they burn well, the desired heat output is achieved by regulating the combustion air.
- If a continuous heating is necessary, fuel is added additionally into the cooker, but only after the volatile materials have burned and the basic firebed is reached.
- **The ash-tray is taken out for cleaning only after it cools down.**

4.5. Ventilation requirements.

An important factor for the right combustion of the cooker is the supply of additional quality of air in the room, which must be minimum 4 m³/h of the kW from the total heat output. If there are other working cookers in the same room, then it is necessary for them additional minimum of 1.6 m³/h air at each hour and at each kW from the total heat output.

A ventilator for suction of the air from the room (desiccators, tumble driers, etc.) working at the same time with the cooker leads to change in the flue draught and consequently to bad burning conditions of the cooker. In this case for the right burning to be achieved it is necessary to let additional air into the room.



If the natural flue draught is insufficient it should be increase by an exhaust ventilator or an additional device.

4.6. Heating during the transitional period.

For the good functioning of the cooker, it is necessary to achieve enough draught of the chimney. This depends on both its height and the environment temperature. If the environment temperature exceeding 14°C disturbances in the combustion caused by insufficient draught might occur. In this case it is necessary to load the cooker with less fuel and the regulators to be left open so that the fuel to be burned faster (with flame) and thus reaching a stable flue draught in the chimney. In this case it is necessary to clean the ashpan more often.

5. Important instructions for fire-precaution and safety regulations.

- The door of the firebox should always be firmly closed even when the cooker is not working.
- The cooker should be installed only on a non-combustible floor.
- The cooker and the chimney pipes should be at least 80 cm away from combustible objects or constructions.
- The top plate of the cooker (frame and plate) should be at least 100 cm away from combustible objects or constructions.
- Using easily inflammable liquids at ignition is not allowed.
- Vertical connection of chimney pipes with the chimney through floor structures is not allowed.
- The presence of easily inflammable and explosive substances in the heated room is not allowed.
- The ash disposal and the cleaning of the cooker should be done only at safe places and when the cooker has cooled down.
- The cooker is intended to local heating of chambers with normal fire hazard.
- It is prohibited to put combustible materials and objects on the cooker or in the immediate proximity of it.
- **The cooker is not intended to be built in kitchen furniture.**
- Please pay attention during the operation of the cooker children to be kept away from it, because its surface is too hot. **Incineration danger!**

We recommend the following instructions in case of a chimney fire:

- Close the combustion air regulator!
- Call the fire brigade in your neighborhood!
- Do not try to extinguish the fire with water by yourself!
- All easily inflammable materials to be away from the chimney!

- When the cooker is set to work again it is necessary the chimney to be checked by a competent person for eventual damages.



When the cooker has been overworked over the limited heat output or for a longer period, and also when using fuels other than the recommended by the manufacturer, then we cannot guarantee reliable work of the cooker.

Please do regularly with the help of a specialist a full check of the cooker related to its functionality. Replace the defected parts only with the spare parts manufactured and supplied by

Do not make any non-authorized changes into construction of the cooker!

6. Cleaning.

The correct maintenance and cleaning of the cooker guarantee its reliable work and keeping its good appearance.

The flue pipes and inner parts of the cooker have to be cleaned at least 1 time per year. Remove the parts pos.№16, №17 and №18 (fig.1) and clean the flue ways and the space below the oven from soot.

The painted surfaces should be cleaned with a dry and soft brush.

The side and top plates of the integral boiler should be cleaned once a month.

Clean the oven when it is still warm.

The glass should be cleaned after cooling down by washing with a soap solution and should be dried afterwards.

While cleaning do not use sharp objects or abrasive materials!

7. Possible defects and their causes.

At ignition the cooker smokes (no enough draught):

- the chimney or the chimney pipes are not sealed;
- incorrectly measured chimney;
- open door of another device connected to the same chimney;

The room cannot get heated:

- greater warmth is needed;
- bad fuel;
- there is too much ash on the grate;
- provided air is insufficient;

The cooker radiates too much heat:

- too much air provided;
- the chimney flue draught is too big;
- high calorific value of the fuel;

The grating is damaged or slag is formed:

- the cooker is overheated repeatedly;
- inappropriate fuel is being used;
- too much primary air is being provided;
- the chimney flue draught is too big;

When the cooker does not work well:

- fully open the primary air control. The secondary air control should be fully opened too;
- load less fuel;
- clean the ashpan regularly;
- check if the chimney is blocked up;
- check if the chimney pipe does not enter the chimney;

- check if the socket of the cooker was not cleaned and if air comes above it;
- if another cooker is connected to the chimney check if it is working properly;
- check if the needed pressure of the flue gases flow of your chimney corresponds to your cooker;

Overheating of the cooker –thermometer reach to 300°C:

- close all air controls and if it is necessary open the oven door.

Oven does not reach high temperature:

- check if the oven door is fully closed;
- check if the ignition flap is closed
- open all air regulators;
- do use good quality wood logs in accordance with point 4.1.

The manufacturer is keeping the right to make changes in the construction without violating the technical and exploiting quality of the cooker.



The manufacturer is not responsible for any changes made on the cooker by the user.

After you had carefully read this instruction, then you can easily use your cooker. We wish you many pleasant and happy hours enjoying the sound of burning and watching the game of the flames.

8. Equipment completion.

The cooker is equipped with:

- Heat-resistant glove -1 pce.
- Operating tool -1 pce.

9. Recycling and waste disposal.

Submit all packaging material for recycling according to the local regulations and requirements. At the end of life cycle of each product its components are due to be disposed of in conformity with regulatory prescriptions. Obsolete equipment shall be collected separately from other recyclable waste containing materials with adverse effect on health and environment. Expired appliances must be collected separately from other recyclable waste containing substances hazardous to health and environment. Both metal and nonmetal parts are sold out to licensed organizations for recyclable metal or non-metal waste collection. In any case they should not be treated as household waste.

Recycling of ceramic glass.

Ceramic glass cannot be recycled. Old glass, breakage or otherwise unusable ceramic glass must be discarded as residual waste. Ceramic glass has a higher melting temperature, and can therefore not be recycled together with glass. If mixed with ordinary glass, it would damage the raw material and could, in worst case end the recycling of glass. It is an important contribution to the environment to ensure that ceramic glass does not end up with the recycling of ordinary glass.

Appendix №1

Representative Family	Nominal heat output												Weight	Seasonal space heating energy efficiency	Energy efficiency index	Energy efficiency class
	Direct heat output	Indirect heat output	Nominal heat output	Max pressure	Useful efficiency at nominal heat output	CO emission	CO emission	PM Emissions	NOx	OGC	Triple value g/s - C° - Pa	Fuel mass				
	Wood (kW)	Wood (kW)	Wood (kW)	(bar)	Wood (%)	Wood (%)	Wood (mg/m ³)	Wood (mg/m ³)	Wood (mg/m ³)	Wood (mg/m ³)	Wood	Wood (kg/h)				
W300	10,5				76,58	0,1157	1446	38,1	88,64	41,5	11,9/188/12	3,18	122	66,58	101,041	A
W300 lux	10,5				76,58	0,1157	1446	38,1	88,64	41,5	11,9/188/12	3,18	125	66,58	101,041	A
W300 lux (color)	10,5				76,58	0,1157	1446	38,1	88,64	41,5	11,9/188/12	3,18	142	66,58	101,041	A
W320 b	5,94	4,01	9,95	2	77,86	0,112	1394	37,5	125	107,9	12,6/184/12	3,151	144	68	103	A

The test results into table are for wood logs with moisture content ≤ 25 %.



LINE STOVES LTD

Bld. Kuklensko shose №12

4004 Plovdiv

Republic of Bulgaria

phone: +359 32 570 041

e-mail: info@linestoves.com

www.linestoves.com